

Name:

Code:

---

2011 Ankara, TURKEY

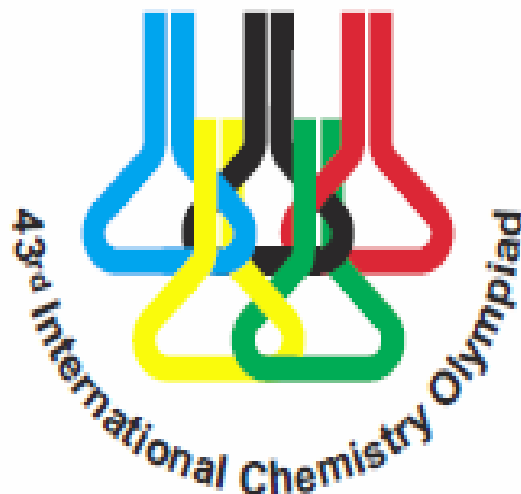

# **43<sup>rd</sup> International Chemistry Olympiad**

# **Theoretical Problems**

**14 July 2011  
Ankara, Turkey**

Name:

Code:

---

# Instructions

- Write your name and code on each page.
- This examination has 8 problems and 32 pages.
- You have 5 hours to work on the problems. **Begin** only when the **START** command is given.
- Use only the pen and the calculator provided.
- All results must be written in the appropriate boxes. Anything written elsewhere will not be graded. Use the reverse of the sheets if you need scratch paper.
- Write relevant calculations in the appropriate boxes when necessary. Full points will be given for right answers with working.
- When you have finished the examination, put your papers into the envelope provided. Do not seal the envelope.
- You must **stop** your work when the **STOP** command is given.
- Do not leave your seat until permitted by the supervisors.
- The official English version of this examination is available on request only for clarification.

Name:

Code:

# Constants and Formulae

Avogadro constant:  $N_A = 6.0221 \times 10^{23} \text{ mol}^{-1}$ Ideal gas equation:  $PV = nRT$ Gas constant:  $R = 8.314 \text{ J} \cdot \text{K}^{-1} \cdot \text{mol}^{-1}$   
 $0.08205 \text{ atm} \cdot \text{L} \cdot \text{K}^{-1} \cdot \text{mol}^{-1}$ Energy of a photon:  $E = \frac{hc}{\lambda}$ Faraday constant:  $F = 96485 \text{ C} \cdot \text{mol}^{-1}$ Gibbs free energy:  $G = H - TS$ Planck constant:  $h = 6.6261 \times 10^{-34} \text{ J} \cdot \text{s}$  $\Delta_r G^\circ = -RT \ln K = -nFE_{\text{cell}}^\circ$  $\Delta H = \Delta E + \Delta nRT$ Speed of light:  $c = 3.000 \times 10^8 \text{ m} \cdot \text{s}^{-1}$ Faraday equation:  $Q = it$ Zero of Celsius scale:  $273.15 \text{ K}$ Arrhenius equation:  $k = Ae^{-E_a/RT}$  $1 \text{ N} = 1 \text{ kg m s}^{-2}$        $1 \text{ eV} = 1.602 \times 10^{-19} \text{ J}$  $K_w = 1.0 \times 10^{-14}$       at  $25^\circ \text{C}$  $1 \text{ atm} = 760 \text{ torr} = 1.01325 \times 10^5 \text{ Pa}$ 

Integrated rate law for the zero order reaction:

 $[A] = [A]_0 - kt$ 

Integrated rate law for the first order reaction:

 $\ln [A] = \ln [A]_0 - kt$ 

## Periodic Table of Elements with Relative Atomic Masses

1 H 1.008																	18 He 4.003
3 Li 6.941	4 Be 9.012											5 B 10.81	6 C 12.01	7 N 14.01	8 O 16.00	9 F 19.00	10 Ne 20.18
11 Na 22.99	12 Mg 24.31	3	4	5	6	7	8	9	10	11	12	13 Al 26.98	14 Si 28.09	15 P 30.97	16 S 32.07	17 Cl 35.45	18 Ar 39.95
19 K 39.10	20 Ca 40.08	21 Sc 44.96	22 Ti 47.87	23 V 50.94	24 Cr 52.00	25 Mn 54.94	26 Fe 55.85	27 Co 58.93	28 Ni 58.69	29 Cu 63.55	30 Zn 65.38	31 Ga 69.72	32 Ge 72.64	33 As 74.92	34 Se 78.96	35 Br 79.90	36 Kr 83.80
37 Rb 85.47	38 Sr 87.62	39 Y 88.91	40 Zr 91.22	41 Nb 92.91	42 Mo 95.96	43 Tc [98]	44 Ru 101.07	45 Rh 102.91	46 Pd 106.42	47 Ag 107.87	48 Cd 112.41	49 In 114.82	50 Sn 118.71	51 Sb 121.76	52 Te 127.60	53 I 126.90	54 Xe 131.29
55 Cs 132.91	56 Ba 137.33	57 La 138.91	72 Hf 178.49	73 Ta 180.95	74 W 183.84	75 Re 186.21	76 Os 190.23	77 Ir 192.22	78 Pt 195.08	79 Au 196.97	80 Hg 200.59	81 Tl 204.38	82 Pb 207.2	83 Bi 208.98	84 Po (209)	85 At (210)	86 Rn (222)
87 Fr (223)	88 Ra 226.0	89 Ac (227)	104 Rf (261)	105 Ha (262)													
58 Ce 140.12	59 Pr 140.91	60 Nd 144.24	61 Pm (145)	62 Sm 150.36	63 Eu 151.96	64 Gd 157.25	65 Tb 158.93	66 Dy 162.50	67 Ho 164.93	68 Er 167.26	69 Tm 168.93	70 Yb 173.05	71 Lu 174.97				
90 Th 232.04	91 Pa 231.04	92 U 238.03	93 Np 237.05	94 Pu (244)	95 Am (243)	96 Cm (247)	97 Bk (247)	98 Cf (251)	99 Es (254)	100 Fm (257)	101 Md (256)	102 No (254)	103 Lr (257)				

**Problem 1****7.0 % of the total**

a	b	c	d			e	Problem 1	x%
			i	ii	iii			
3	2	6	6	1.5	1	2.5	22	7.0

Nitrogen oxides, common pollutants in the ambient air, are primarily nitric oxide, NO, and nitrogen dioxide, NO<sub>2</sub>. Atmospheric nitric oxide is produced mainly during thunderstorms and in the internal combustion engines. At high temperatures NO reacts with H<sub>2</sub> to produce nitrous oxide, N<sub>2</sub>O, a greenhouse gas.

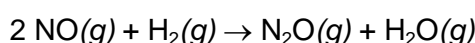

To study the kinetics of this reaction at 820 °C, initial rates for the formation of N<sub>2</sub>O were measured using various initial partial pressures of NO and H<sub>2</sub>.

Exp.	Initial pressure, torr		Initial rate of production of N <sub>2</sub> O, torr·s <sup>-1</sup>
	P <sub>NO</sub>	P <sub>H<sub>2</sub></sub>	
1	120.0	60.0	8.66×10 <sup>-2</sup>
2	60.0	60.0	2.17×10 <sup>-2</sup>
3	60.0	180.0	6.62×10 <sup>-2</sup>

**Throughout this problem do not use concentrations. Use units of pressure in torr and time in seconds.**

a. Determine the experimental rate law and calculate the rate constant.

$$\text{Rate} = R = k(P_{\text{NO}})^a(P_{\text{H}_2})^b$$

$$\frac{R_1}{R_2} = \frac{8.66 \times 10^{-2}}{2.17 \times 10^{-2}} = 3.99 = \frac{k \times 120^a \times 60^b}{k \times 60^a \times 60^b} \quad 2^a = 3.99 \Rightarrow a = 2$$

$$\frac{R_3}{R_2} = \frac{6.62 \times 10^{-2}}{2.17 \times 10^{-2}} = 3.05 = \frac{k \times 60^a \times 180^b}{k \times 60^a \times 60^b} \quad 3^b = 3.05 \Rightarrow b = 1$$

$$\text{Rate} = k(P_{\text{NO}})^2(P_{\text{H}_2})$$

$$k = \frac{8.66 \times 10^{-2}}{120^2 \times 60} = 1.00 \times 10^{-7} \text{ torr}^{-2} \cdot \text{s}^{-1} \quad (2.5 + 0.5 \text{ pt})$$

Name:

Code:

- b. Calculate the initial rate of disappearance of NO, if  $2.00 \times 10^2$  torr NO and  $1.00 \times 10^2$  torr  $H_2$  are mixed at  $820^\circ C$ . (If you do not have the value for the rate constant then use  $2 \times 10^{-7}$  in appropriate unit.)

$$\text{Rate} = \frac{\Delta P_{N_2O}}{\Delta t} = -1/2 \frac{\Delta P_{NO}}{\Delta t} = 1.0 \times 10^{-7} \times 200^2 \times 100 = 0.40 \text{ torr} \cdot \text{s}^{-1}$$

$$-\frac{\Delta P_{NO}}{\Delta t} = 0.80 \text{ torr} \cdot \text{s}^{-1} \quad (1.5+0.5 \text{ pt})$$

- c. Calculate the time elapsed to reduce the partial pressure of  $H_2$  to the half of its initial value, if  $8.00 \times 10^2$  torr NO and 1.0 torr of  $H_2$  are mixed at  $820^\circ C$ . (If you do not have the value for the rate constant then use  $2 \times 10^{-7}$  in appropriate unit.)

$$\text{Rate} = k(P_{NO})^2 P_{H_2}$$

$$\text{as } P_{NO} \gg P_{H_2}$$

$$\text{Rate} = k' P_{H_2} \Rightarrow k' = k(P_{NO})^2$$

$$k' = 1.0 \times 10^{-7} \times (8.00 \times 10^2)^2 = 0.064 \text{ s}^{-1}$$

$$t_{1/2} = \frac{\ln 2}{k'} = 10.8 \text{ s} \quad (5.5+0.5 \text{ pt})$$

- d. A proposed mechanism for the reaction between NO and  $H_2$  is given below:

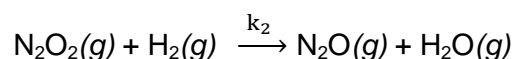
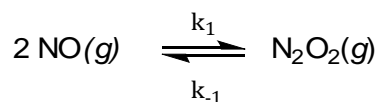

Name:

Code:

- i. Derive the rate law for the formation of  $N_2O$  from the proposed mechanism using the steady-state approximation for the intermediate.

$$\frac{\Delta P_{N_2O}}{\Delta t} = k_2(P_{N_2O_2})(P_{H_2})$$

steady state approximation for  $N_2O_2$

$$\frac{\Delta P_{N_2O_2}}{\Delta t} = 0 = k_1(P_{NO})^2 - k_{-1}P_{N_2O_2} - k_2P_{N_2O_2}P_{H_2} = 0$$

$$P_{N_2O_2} = \frac{k_1(P_{NO})^2}{k_{-1} + k_2P_{H_2}}$$

$$\frac{\Delta P_{N_2O}}{\Delta t} = k_2P_{H_2} \frac{k_1(P_{NO})^2}{k_{-1} + k_2P_{H_2}}$$

$$\text{Rate} = \frac{\Delta P_{N_2O}}{\Delta t} = k_1 k_2 \frac{(P_{NO})^2 P_{H_2}}{k_{-1} + k_2 P_{H_2}} \quad (6 \text{ pt})$$

- ii. Under what condition does this rate law reduce to the experimentally determined rate law found in Part a?

If  $k_{-1} \ll k_2 P_{H_2}$

If  $k_{-1} \gg k_2 P_{H_2}$

If  $k_{-1} > k_2$

If  $k_1 > k_{-1}$

(1.5 pt)

Name:

Code:

iii. Express the experimentally determined rate constant  $k$  in terms of  $k_1$ ,  $k_{-1}$  and  $k_2$ .

$$k = \frac{k_1 k_2}{k_{-1}}$$

(1 pt)

e. Select the schematic energy diagram that is consistent with the proposed reaction mechanism and experimental rate law.

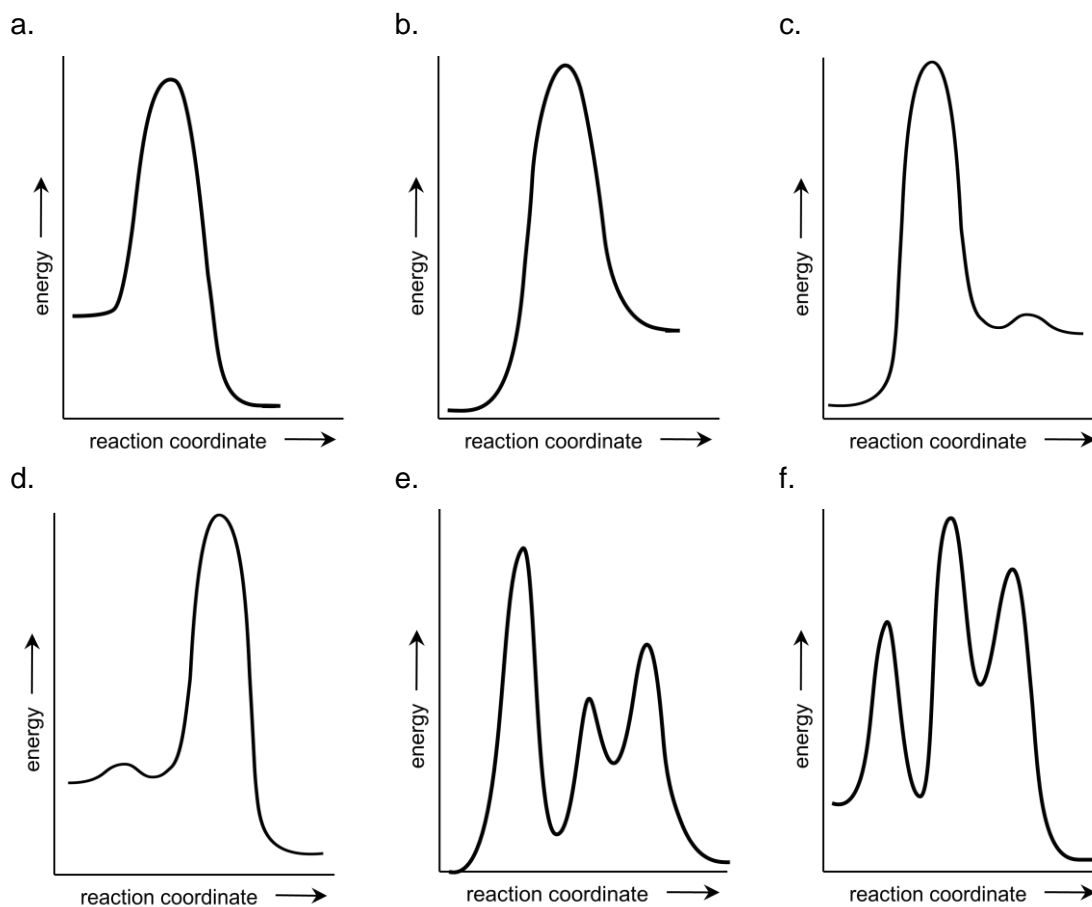

a)                      b)                      c)                      ✓ d)                      e)                      f)                      (2.5 pt)

**Problem 2****7.0 % of the total**

a	b			Problem 2	x%
	i	ii	iii		
6	9	6	2	23	7.0

Anhydrous ammonia is an ultra-clean, energy-dense alternative liquid fuel. It produces no greenhouse gases on combustion.

In an experiment, gaseous  $\text{NH}_3$  is burned with  $\text{O}_2$  in a container of fixed volume according to the equation given below.

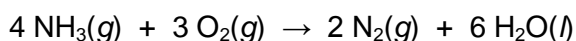

The initial and final states are at 298 K. After combustion with 14.40 g of  $\text{O}_2$ , some of  $\text{NH}_3$  remains unreacted.

- a. Calculate the heat given out during the process.

Given:  $\Delta_f H^\circ(\text{NH}_3(g)) = -46.11 \text{ kJ}\cdot\text{mol}^{-1}$  and  $\Delta_f H^\circ(\text{H}_2\text{O}(l)) = -285.83 \text{ kJ}\cdot\text{mol}^{-1}$

$$q_v = \Delta E = \Delta H - \Delta n_g RT$$

for 1 mole of  $\text{NH}_3$

$$\Delta H = 3/2 \times (-285.83) - (-46.11) = -382.64 \text{ kJ}$$

$$\Delta n_g = -1.25 \text{ mol}$$

$$\Delta E = -382.64 - (-1.25) \times 8.314 \times 298 \times 10^{-3}$$

$$= -379.5 \text{ kJ for 1 mol of NH}_3$$

$$n(\text{O}_2) = \frac{14.40}{32.0} = 0.450 \text{ mol}$$

$$n(\text{NH}_3) \text{ reacted} = 0.450 \left( \frac{4}{3} \right) = 0.600 \text{ mol}$$

$$q_v = \Delta E = 0.600 \times (-379.5) = -227.7 \text{ kJ} = -228 \text{ kJ}$$

heat given out = **228 kJ**

(6 pt)



Name:

Code:

- b. To determine the amount of  $\text{NH}_3$  gas dissolved in water, produced during the combustion process, a 10.00 mL sample of the aqueous solution was withdrawn from the reaction vessel and added to 15.0 mL of 0.0100 M  $\text{H}_2\text{SO}_4$  solution. The resulting solution was titrated with 0.0200 M standard NaOH solution and the equivalence point was reached at 10.64 mL. ( $K_b(\text{NH}_3) = 1.8 \times 10^{-5}$ ;  $K_a(\text{HSO}_4^-) = 1.1 \times 10^{-2}$ )
- i. Calculate pH of the solution in the container after combustion.

$$\text{Total mmol H}_2\text{SO}_4 = (15.00 \text{ mL})(0.0100 \text{ mol}\cdot\text{L}^{-1}) = 0.150 \text{ mmol H}_2\text{SO}_4$$



After back titration with NaOH,

$$\text{mmol H}_2\text{SO}_4 \text{ reacted} = \frac{1}{2}(\text{mmol NaOH reacted}) = \frac{1}{2} (10.64 \text{ mL} \times 0.0200 \text{ mol}\cdot\text{L}^{-1})$$

$$\text{mmol H}_2\text{SO}_4 \text{ reacted} = 0.1064 \text{ mmol H}_2\text{SO}_4$$

$$\text{Total mmol H}_2\text{SO}_4 = 0.1064 \text{ mmol} + \text{mmol H}_2\text{SO}_4 \text{ reacted with NH}_3 = 0.150 \text{ mmol H}_2\text{SO}_4$$

$$\text{mmol H}_2\text{SO}_4 \text{ reacted with NH}_3 = 0.0436 \text{ mmol H}_2\text{SO}_4$$

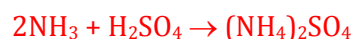

$$\text{mmol NH}_3 = 2(\text{mmol H}_2\text{SO}_4 \text{ reacted with NH}_3) = 2(0.0436 \text{ mmol NH}_3) = 0.0872 \text{ mmol NH}_3$$

$$[\text{NH}_3] = \frac{0.0872 \text{ mmol}}{10.0 \text{ mL}} = 8.72 \times 10^{-3} \text{ M}$$



$$[\text{NH}_3]_0 - x \qquad \qquad \qquad x \qquad \qquad x$$

$$K_b = 1.8 \times 10^{-5} = \frac{x^2}{(0.00872 - x)}$$

$$-1.57 \times 10^{-7} + 1.8 \times 10^{-5}x + x^2 = 0$$

$$x = \frac{-1.8 \times 10^{-5} \pm \sqrt{(1.8 \times 10^{-5})^2 + 4 \times 1.57 \times 10^{-7}}}{2}$$

$$x = [\text{OH}^-] = 3.96 \times 10^{-4} \text{ mol}\cdot\text{L}^{-1}$$

$$\text{pOH} = -\log[\text{OH}^-] = 3.41$$

$$\text{pH} = 14.00 - 3.41 = 10.59$$

(9 pt)

Name:

Code:

- ii. At the end point of titration,  $\text{NH}_4^+$  and  $\text{SO}_4^{2-}$  ions are present in the solution. Write the equations for the relevant equilibria to show how the presence of these two ions affect the pH and calculate their equilibrium constant(s).



$$K_b = \frac{K_w}{K_a} = \frac{1.0 \times 10^{-14}}{1.1 \times 10^{-2}} = 9.1 \times 10^{-13}$$



$$K_a = \frac{K_w}{K_b} = \frac{1.0 \times 10^{-14}}{1.8 \times 10^{-5}} = 5.6 \times 10^{-10}$$

(6 pt)

- iii. Circle the correct statement for the pH of solution at the equivalence point.

(2 pt)

pH > 7.0

pH = 7.0

pH < 7.0

**Problem 3****8.0 % of the total**

a	b	c		d	Problem 3	x%
		i	ii			
7	4	2	5	5	23	8.0

At 0 K, the total energy of a gaseous diatomic molecule AB is approximately given by:

$$E = E_0 + E_{\text{vib}}$$

where  $E_0$  is the electronic energy of the ground state, and  $E_{\text{vib}}$  is the vibrational energy.

Allowed values of the vibrational energies are given by the expression:

$$E_{\text{vib}} = \left(v + \frac{1}{2}\right) \varepsilon \quad v = 0, 1, 2, \dots \quad \varepsilon = \frac{h}{2\pi} \sqrt{\frac{k}{\mu}} \quad \mu(\text{AB}) = \frac{m_A m_B}{m_A + m_B}$$

where  $h$  is the Planck's constant,  $v$  is the vibrational quantum number,  $k$  is the force constant, and  $\mu$  is the reduced mass of the molecule. At 0 K, it may be safely assumed that  $v$  is zero, and  $E_0$  and  $k$  are independent of isotopic substitution in the molecule.

- a. Calculate the enthalpy change,  $\Delta H$ , in  $\text{kJ}\cdot\text{mol}^{-1}$  for the following reaction at 0 K.

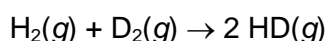

Deuterium, D, is an isotope of hydrogen atom with mass number 2. For the  $\text{H}_2$  molecule,  $k$  is  $575.11 \text{ N}\cdot\text{m}^{-1}$ , and the isotopic molar masses of H and D are  $1.0078$  and  $2.0141 \text{ g}\cdot\text{mol}^{-1}$ , respectively. Given:  $\varepsilon_{\text{H}_2} = 1.1546 \varepsilon_{\text{HD}}$  and  $\varepsilon_{\text{D}_2} = 0.8167 \varepsilon_{\text{HD}}$  at 0 K.



$$\Delta H = \Delta E + \Delta n_g RT \quad \Delta n_g = 0 \quad \text{Thus } \Delta H = \Delta E$$

$$\Delta E = 2E(\text{HD}) - E(\text{H}_2) - E(\text{D}_2)$$

$$E_{\text{vib}} = \frac{1}{2} \varepsilon \quad \text{as } v = 0 \text{ at } 0 \text{ K}$$

$$\Delta E = 2\left(E_0 + \frac{\varepsilon_{\text{HD}}}{2}\right) - \left(E_0 + \frac{\varepsilon_{\text{H}_2}}{2}\right) - \left(E_0 + \frac{\varepsilon_{\text{D}_2}}{2}\right) = \varepsilon_{\text{HD}} - \frac{1}{2}(\varepsilon_{\text{H}_2} + \varepsilon_{\text{D}_2})$$

$$\Delta E = \varepsilon_{\text{HD}} \left(1 - \frac{1}{2}(1.1546 + 0.8167)\right) = 0.01435 \varepsilon_{\text{HD}}$$

$$\mu(\text{HD}) = \frac{m_{\text{H}} m_{\text{D}}}{m_{\text{H}} + m_{\text{D}}}$$

$$= \frac{1.0078 \times 10^{-3} \text{ kg} \cdot \text{mol}^{-1} \times 2.0141 \times 10^{-3} \text{ kg} \cdot \text{mol}^{-1} / N_A^2}{(1.0078 \times 10^{-3} \text{ kg} \cdot \text{mol}^{-1} + 2.0141 \times 10^{-3} \text{ kg}) / N_A}$$

$$= 1.1154 \times 10^{-27} \text{ kg}$$

$$\varepsilon_{HD} = \frac{h}{2\pi} \sqrt{\frac{k}{\mu}} = \frac{6.6261 \times 10^{-34} \text{ J} \cdot \text{s}}{2\pi} \times \sqrt{\frac{575.11 \text{ N} \cdot \text{m}^{-1}}{1.1154 \times 10^{-27} \text{ kg}}}$$

$$= 7.5724 \times 10^{-20} \text{ J}$$

$$\varepsilon_{HD} = 7.5724 \times 10^{-20} \text{ J} \times N_A$$

$$= 7.5724 \times 10^{-20} \text{ J} \times 6.0221 \times 10^{23} \times \frac{1 \text{ kJ}}{1000 \text{ J}}$$

$$= 45.600 \text{ kJ} \cdot \text{mol}^{-1}$$

$$\Delta H = \Delta E = 0.01435 \varepsilon_{HD} = 0.6544 \text{ kJ} \cdot \text{mol}^{-1} \quad (7 \text{ pt})$$

- b. Calculate the frequency in  $\text{s}^{-1}$  of infrared photons that can be absorbed by HD molecule. (If you do not have the value for  $\varepsilon_{HD}$  then use  $8.000 \times 10^{-20} \text{ J}$  for the calculation.)

$$h\nu = \Delta E$$

$$\Delta E = E_{v1} - E_{v0} = \left(\frac{3}{2} - \frac{1}{2}\right) \varepsilon_{HD} = \varepsilon_{HD}$$

$$h\nu = \varepsilon_{HD} \quad \Rightarrow \quad \nu = \frac{\varepsilon_{HD}}{h}$$

$$\varepsilon_{HD} = 7.5724 \times 10^{-20} \text{ J} \text{ from part a}$$

$$\nu = \frac{7.5724 \times 10^{-20} \text{ J}}{6.6261 \times 10^{-34} \text{ J} \cdot \text{s}} = 1.1428 \times 10^{14} \text{ s}^{-1} \quad (4 \text{ pt})$$

- c. The allowed electronic energies of H atom are given by the expression

$$E = -\frac{R_H}{n^2}, \quad n = 1, 2, \dots \quad \text{where } R_H = 13.5984 \text{ eV}, \quad 1 \text{ eV} = 1.602 \times 10^{-19} \text{ J}$$

- i. The total energy of H<sub>2</sub> molecule in its ground state is -31.675 eV, relative to the same reference as that of hydrogen atom. Calculate the dissociation energy in eV of a hydrogen molecule in its ground state such that both H atoms are produced in their ground states.



$$\text{For } n = 1, \Delta E = 2(-13.5984) - (-31.675) = 4.478 \text{ eV}$$

(2 pt)

- ii. A H<sub>2</sub> molecule in the ground state dissociates into its atoms after absorbing a photon of wavelength 77.0 nm. Determine all possibilities for the electronic states of H atoms produced. In each case, what is the total kinetic energy in eV of the dissociated hydrogen atoms?

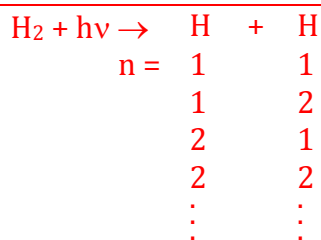

The energy of H<sub>2</sub> molecule in its ground state is -31.675 eV

$\lambda = 77.0 \text{ nm}$

$$E(\text{photon}) = \frac{hc}{\lambda} = \frac{(6.6261 \times 10^{-34})(3.00 \times 10^8)}{77.0 \times 10^{-9}} = 2.58 \times 10^{-18} \text{ J}$$

$$= 2.58 \times 10^{-18} \text{ J} \frac{1 \text{ eV}}{1.602 \times 10^{-19} \text{ J}} = 16.1 \text{ eV}$$

$$\Delta E = E_{n_1} + E_{n_2} - E_{\text{H}_2} = -\frac{R_H}{n_1^2} - \frac{R_H}{n_2^2} - (-31.675) < 16.1 \text{ eV}$$

$n_1 = 1, n_2 = 1,$

$$\Delta E = -\frac{13.5984}{1^2} - \frac{13.5984}{1^2} + 31.675 = 4.478 \text{ eV};$$

$$\text{K.E.} = 16.1 - 4.478 = 11.6 \text{ eV}$$

$n_1 = 1, n_2 = 2$  or  $n_1 = 2, n_2 = 1,$

$$\Delta E = -\frac{13.5984}{1^2} - \frac{13.5984}{2^2} + 31.675 = 14.677 \text{ eV};$$

$$\text{K.E.} = 16.1 - 14.677 = 1.4 \text{ eV}$$

$$n_1 = 2, n_2 = 2, \quad \Delta E = -\frac{13.5984}{2^2} - \frac{13.5984}{2^2} + 31.675 = 24.880 \text{ eV} > 16.1 \text{ eV}$$

(5 pt)

Thus possibilities are

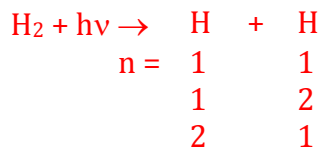

Name:

Code:

- d. Calculate the electron affinity of  $\text{H}_2^+$  ion in eV if its dissociation energy is 2.650 eV. (If you do not have the value for the dissociation energy for  $\text{H}_2$  then use 4.500 eV for the calculation.)

$$\text{IP}(\text{H}) = \Delta E_{n \rightarrow \infty} = -\frac{13.5984}{\infty^2} - \frac{-13.5984}{1^2} = 13.598 \text{ eV}$$

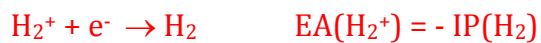

$$\text{EA}(\text{H}_2^+) = \text{DE}(\text{H}_2^+) - \text{IP}(\text{H}) - \text{DE}(\text{H}_2) = 2.650 - 13.598 - 4.478 = -15.426 \text{ eV}$$

Electron affinity = -15.426 eV

(5 pt)

**Problem 4****9.0% of the total**

a	b	c	d	e	f	g	Problem 4	x%
4	3	6	3	4	6	4	30	9.0

For sustainable energy, hydrogen appears to be the best energy carrier. The most efficient way of using hydrogen is generation of electrical energy in a fuel cell. However, storing hydrogen in large quantities is a challenge in fuel cell applications. Among the chemical hydrides considered as solid hydrogen storage materials, sodium borohydride ( $\text{NaBH}_4$ ), being nontoxic, stable and environmentally benign, appears to be the most promising one. The hydrolysis of sodium borohydride that releases  $\text{H}_2$  gas is a slow reaction at ambient temperature and, therefore, needs to be catalyzed.

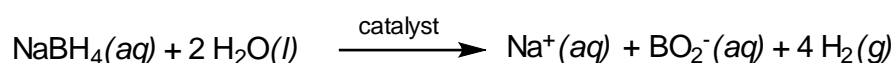

Colloidal ruthenium(0) nanoclusters are the most active catalysts in this hydrolysis even at room temperature and lead to a complete  $\text{H}_2$  release from sodium borohydride. Kinetic studies show that the catalytic hydrolysis of  $\text{NaBH}_4$  is first order with respect to the catalyst, but zero order with respect to the substrate. The rate of hydrogen production per mole of ruthenium is  $92 \text{ mol H}_2 \cdot (\text{mol Ru})^{-1} \cdot \text{min}^{-1}$  at  $25^\circ\text{C}$ .

- a. Calculate the amount of ruthenium catalyst (in mg) which must be added to  $0.100 \text{ L}$  solution of  $1.0 \text{ mol} \cdot \text{L}^{-1}$   $\text{NaBH}_4$  to supply the hydrogen gas at a rate of  $0.100 \text{ L} \cdot \text{min}^{-1}$  at  $25^\circ\text{C}$  and  $1.0 \text{ atm}$ , that is required for a portable fuel cell.

$$n_{\text{H}_2} = \frac{(100 \times 10^{-3} \text{ L} \cdot \text{min}^{-1}) \times (1.0 \text{ atm})}{(0.082 \text{ atm} \cdot \text{L} \cdot \text{K}^{-1} \cdot \text{mol}^{-1})(298 \text{ K})} = 4.1 \times 10^{-3} \text{ mol H}_2 \cdot \text{min}^{-1}$$

$$\frac{(4.1 \times 10^{-3} \text{ mol H}_2 \cdot \text{min}^{-1})}{(92 \text{ mol H}_2 \cdot (\text{mol Ru})^{-1} \cdot \text{min}^{-1})} = 4.5 \times 10^{-5} \text{ mol Ru}$$

$$(4.5 \times 10^{-5} \text{ mol Ru}) \times (101.07 \text{ g} \cdot \text{mol}^{-1}) = 4.5 \times 10^{-3} \text{ g Ru} = 4.5 \text{ mg Ru}$$

(4 pt)



Name:

Code:

b. For how many minutes will this system supply hydrogen gas at this rate?

$$(1.00 \times 10^{-1} \text{L}) \times (1.0 \text{ mol} \cdot \text{L}^{-1}) = 0.10 \text{ mol NaBH}_4$$

$$(0.10 \text{ mol NaBH}_4) \times 4 \text{ mol H}_2 \cdot (\text{mol NaBH}_4)^{-1} = 0.40 \text{ mol H}_2 \text{ to be released}$$

$$\frac{(0.40 \text{ mol H}_2)}{(4.1 \times 10^{-3} \text{ mol H}_2 \cdot \text{min}^{-1})} = 98 \text{ min}$$

(3 pt)

c. The Arrhenius activation energy for this catalytic hydrolysis of sodium borohydride is  $E_a = 42.0 \text{ kJ} \cdot \text{mol}^{-1}$ . Calculate the temperature required to achieve the same rate of hydrogen evolution by using half the amount of ruthenium catalyst used at  $25.0 \text{ }^\circ\text{C}$ .

$$\text{Rate} = k[\text{Ru}] = (Ae^{-E_a/RT})[\text{Ru}]$$

$$\frac{(e^{-E_a/R298})}{(e^{-E_a/RT})} = \frac{1}{2}$$

$$-\frac{E_a}{R} \left( \frac{1}{298} - \frac{1}{T} \right) = \ln\left(\frac{1}{2}\right), \quad \frac{4.20 \times 10^4 \text{ J} \cdot \text{mol}^{-1}}{8.314 \text{ J} \cdot \text{K}^{-1} \cdot \text{mol}^{-1}} \left( \frac{1}{298} - \frac{1}{T} \right) = \ln(2),$$

$$T = 311 \text{ K or } T = 38 \text{ }^\circ\text{C}$$

(6 pt)

d. A fuel cell is made up of three segments sandwiched together: the anode, the electrolyte, and the cathode. Hydrogen is used as fuel and oxygen as oxidant. Two chemical reactions occur at the interfaces of the three different segments.

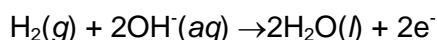
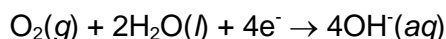

The net result of the two reactions is

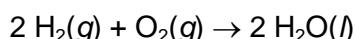

The hydrogen for the fuel cell is supplied from the hydrolysis of sodium borohydride.

Calculate the standard potential for the cathode half reaction if the standard reduction potential for the anode half reaction is  $-0.83 \text{ V}$  and  $\Delta_f G^\circ (\text{H}_2\text{O}(\text{l}))$  is  $-237 \text{ kJ} \cdot \text{mol}^{-1}$ .

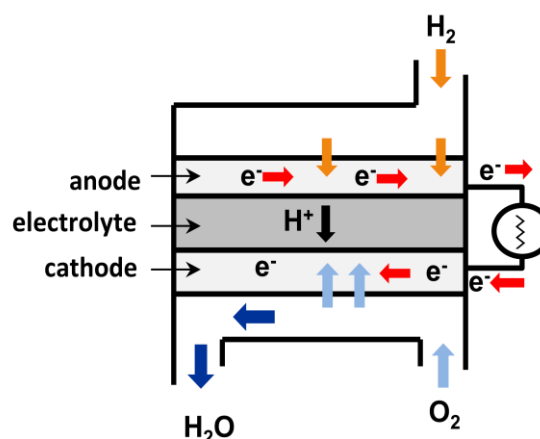

Name:

Code:

Since  $\Delta G^\circ = -nFE^\circ$

$$2(-2.37 \times 10^5) = -4 \times 96485 \times E^\circ_{\text{cell}} \quad E^\circ_{\text{cell}} = +1.23 \text{ V}$$

$$1.23 \text{ V} = E^\circ_{\text{cathode}} - (-0.83) \quad E^\circ_{\text{cathode}} = +0.40 \text{ V} \quad (3 \text{ pt})$$

- e. Calculate the volume of air at 25 °C and 1.0 atm needed to generate a constant current of 2.5 A for 3.0 h in this fuel cell. Assume that air contains 20% by volume  $\text{O}_2(\text{g})$ .

$$(2.5 \text{ A}) \times (3.0 \text{ h}) \times (3600 \text{ s} \cdot \text{h}^{-1}) = 27000 \text{ C}$$

$$n(\text{O}_2) = (27000 \text{ C}) \times \left( \frac{1 \text{ mol O}_2}{4 \times 96485 \text{ C}} \right) = 0.070 \text{ mol}$$

$$V(\text{O}_2) = \frac{(0.070 \text{ mol}) \times (0.082 \text{ atm} \cdot \text{L} \cdot \text{K}^{-1} \cdot \text{mol}^{-1}) \times (298 \text{ K})}{(1.0 \text{ atm})} = 1.7 \text{ L} \quad V_{\text{air}} = 8.6 \text{ L} \quad (4 \text{ pt})$$

- f. The efficiency of a fuel cell is given by the ratio of the work produced to the heat dissipated by the cell reaction. Thus, the maximum efficiency for a fuel cell is given by:

$$\eta_{\text{fuel cell}} = \frac{\text{work}}{\text{heat}}$$

Calculate the maximum efficiency for the fuel cell using the data given below at 25 °C and standard pressure.

	$S^\circ$ ( $\text{J} \cdot \text{mol}^{-1} \cdot \text{K}^{-1}$ )
$\text{H}_2(\text{g})$	130.7
$\text{O}_2(\text{g})$	205.2
$\text{H}_2\text{O}(\text{l})$	70.0

$$\Delta_{\text{rxn}}G^\circ = \Delta_{\text{rxn}}H^\circ - T\Delta_{\text{rxn}}S^\circ$$

$$\Delta_{\text{rxn}}S^\circ = [2 \times S^\circ(\text{H}_2\text{O}(l))] - [2S^\circ(\text{H}_2(g)) + S^\circ(\text{O}_2(g))] = 2 \times 70.0 - (2 \times 130.7 + 205.2) =$$

$$\Delta_{\text{rxn}}S^\circ = -326.6 \text{ J}\cdot\text{mol}^{-1}\cdot\text{K}^{-1}$$

$$\Delta_{\text{rxn}}H^\circ = \Delta_{\text{rxn}}G^\circ + T\Delta_{\text{rxn}}S^\circ = (-474) + 298.15 \times (-326.6 \times 10^{-3}) = -571.4 \text{ kJ}$$

$$\text{maximum } w = \Delta_{\text{rxn}}G^\circ = -474 \text{ kJ}$$

$$\eta = \frac{-474000 \text{ J}}{-571400 \text{ J}} = 0.83$$

(6 pt)

- g. The second law of thermodynamics states that it is impossible to convert all of the heat,  $q_H$ , from a high-temperature reservoir at  $T_H$  into work. At least, some of the energy,  $q_C$ , must be transferred to a low-temperature reservoir at  $T_C$ . Thus, a heat engine with 100% efficiency is thermodynamically impossible. When the heat engine is working reversibly, as in a Carnot cycle, the efficiency will be maximum.

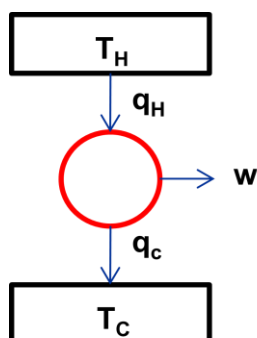

For a heat engine working reversibly between two reservoirs the following relations applies:

$$q_H = w + q_C$$

and

$$\frac{q_H}{T_H} = \frac{q_C}{T_C}$$

What should be the temperature of the hot reservoir,  $T_H$ , of a Carnot heat engine to maintain the efficiency of the fuel cell calculated in part (f), if the temperature of cold reservoir  $T_C$  is 40 °C? (If you do not have the value for the efficiency then use 0.80)

$$\eta_{\text{engine}} = \frac{w}{q_H} = \frac{q_H - q_C}{q_H} = 1 - \frac{q_C}{q_H}$$

$$\text{Since } \frac{q_H}{T_H} = \frac{q_C}{T_C} \quad \frac{q_C}{q_H} = \frac{T_C}{T_H}$$

$$\text{Thus; } \eta_{\text{engine}} = 1 - \frac{T_C}{T_H}$$

$$0.83 = 1 - \frac{313}{T_H} \quad T_H = 1.8 \times 10^3 \text{ K or } T_H = 1.6 \times 10^3 \text{ }^\circ\text{C}$$

(4 pt)

**Problem 5****7.0% of the total**

a		b	c	d	e	f	g	Problem 5	x%
i	ii	1	6	5	2	2	6	30	7.0
5	3								

Polynitrogen compounds have great potential for being used as high energy density materials. They are thermodynamically unstable. Huge amount of energy is released from their decomposition or reactions leading to more stable products. The only known polynitrogen species are  $N_2$ ,  $N_3^-$  and  $N_5^+$ , isolated in 1772, 1890 and 1999, respectively, and the recently reported cyclic anion,  $N_5^-$ .

- a. (i) Write the Lewis structure for  $N_5^+$  with three energetically favorable resonance forms. Indicate the lone pairs and formal charges. Draw the molecular geometry of  $N_5^+$ .

 $N_5^+$ 

Lewis Structure

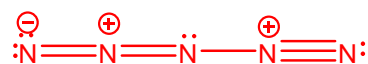
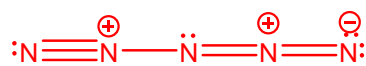
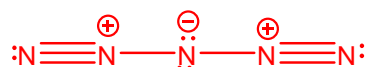

The molecular geometry

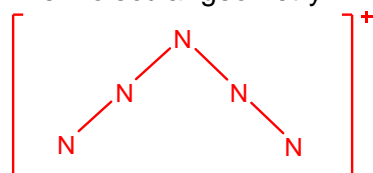

5 point

Name:

Code:

(ii) Write the Lewis structures for cyclic  $N_5^-$  with five energetically favorable resonance forms. Indicate the lone pairs and formal charges. Draw the molecular geometry of cyclic  $N_5^-$ .

Cyclic  $N_5^-$

Lewis Structure

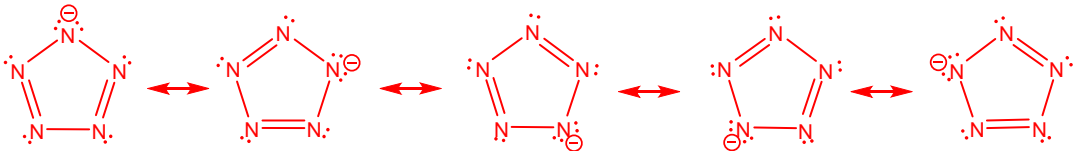

The molecular geometry

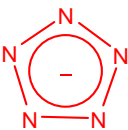

(3 pt)

b. The synthesis of  $[N_5^+][AsF_6^-]$ , a white ionic solid, was achieved by reacting  $[N_2F^+][AsF_6^-]$  with hydrazoic acid,  $HN_3$ , in liquid HF at  $-78\text{ }^\circ\text{C}$ . Write the balanced chemical equation for this reaction.

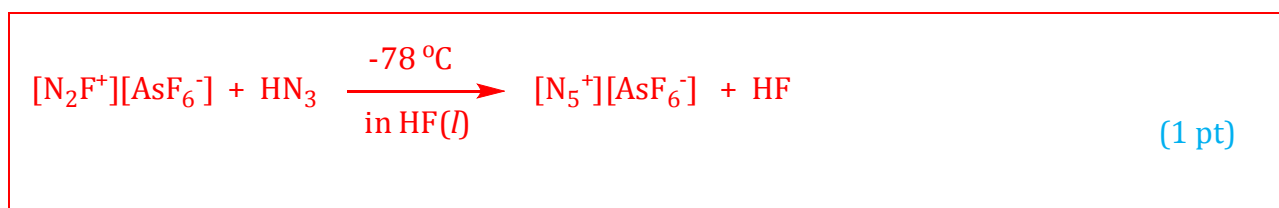

The preparation of  $[N_2F^+][AsF_6^-]$  requires the reaction of  $N_2F_2$  with strong Lewis acid,  $AsF_5$ , as follows:

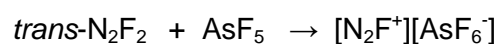
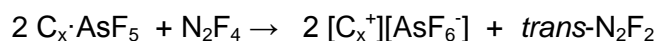

In the synthesis of  $N_2F_2$ , the *trans* isomer is formed, which is thermodynamically less stable than *cis*- $N_2F_2$ . However, conversion of *trans*- $N_2F_2$  to *cis*- $N_2F_2$  requires surmounting a high energy barrier of 251 kJ/mol, so that equilibration between the *cis* and the *trans* isomers does not significantly take place without a suitable catalyst.

When *trans*- $N_2F_2$  is maintained in a closed container for 6 days at room temperature, in the presence of a small amount of  $SbF_5$  as a catalyst, *cis*-*trans* thermal equilibrium is established.

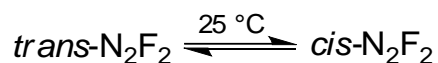

The standard enthalpies of formation of *trans*- and *cis*-N<sub>2</sub>F<sub>2</sub> are 67.31 and 62.03 kJ/mol, respectively, and their standard entropies at 25 °C are 262.10 and 266.50 J·K<sup>-1</sup>·mol<sup>-1</sup>, respectively.

- c. Find the ratio of the number of *cis*-N<sub>2</sub>F<sub>2</sub> molecules over that of the *trans*-N<sub>2</sub>F<sub>2</sub> molecules in an equilibrium mixture at 25 °C.

The desired ratio is the value of the equilibrium constant, *K*, of the *trans*→*cis* reaction shown above.

$$K = \frac{[\textit{cis}]}{[\textit{trans}]}$$

$$\Delta G^\circ = -RT \ln K$$

$$\Delta G^\circ = \Delta H^\circ - T\Delta S^\circ$$

$$\Delta H^\circ = 62.03 - 67.31 = -5.28 \text{ kJ}\cdot\text{mol}^{-1}$$

$$\Delta S^\circ = 266.50 - 262.10 = 4.40 \text{ J}\cdot\text{K}^{-1}\cdot\text{mol}^{-1}$$

$$\Delta G^\circ = -5.28 \times 10^3 - (298)(4.40) = -6.59 \times 10^3 \text{ J}\cdot\text{mol}^{-1}$$

$$K = e^{-\Delta G^\circ/RT} = e^{-(-6.59 \times 10^3)/(8.314 \times 298)} = 14.3$$

$$\frac{[\textit{cis}]}{[\textit{trans}]} = 14.3 \text{ at } 25\text{ }^\circ\text{C}.$$

(6 pt)

- d. Write the Lewis structures showing the geometry of the N<sub>2</sub>F<sup>+</sup> ion and of the *trans*- and *cis*-isomers of N<sub>2</sub>F<sub>2</sub>. Include all lone pairs and formal charges. Suggest an appropriate hybridization for each nitrogen atom in N<sub>2</sub>F<sub>2</sub> and N<sub>2</sub>F<sup>+</sup>.

Name:

Code:

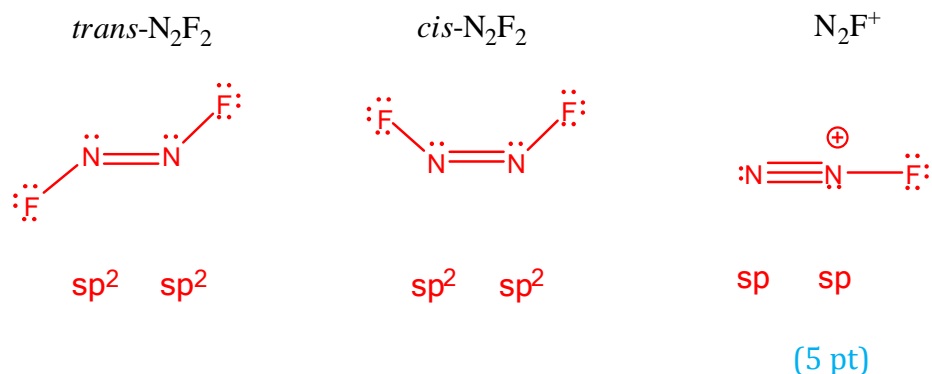

Solid  $[\text{N}_5^+][\text{AsF}_6^-]$  is marginally stable at room temperature but reacts explosively with water to produce arsenic pentafluoride, hydrogen fluoride, molecular nitrogen and oxygen.

e. Write a balanced equation for the reaction between  $[\text{N}_5^+][\text{AsF}_6^-]$  and water.



Conversion of  $[\text{N}_5^+][\text{SbF}_6^-]$  into other  $\text{N}_5^+$  salts can be achieved by a metathesis reaction:

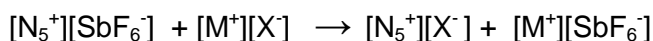

$\text{M}^+ = \text{Na}^+, \text{K}^+, \text{Cs}^+$ ;  $\text{X}^- =$  large anion such as  $\text{SnF}_6^{2-}$  and  $\text{B}(\text{CF}_3)_4^-$ .

Since  $[\text{Cs}^+][\text{SbF}_6^-]$  has a low solubility in anhydrous HF, and  $[\text{K}^+][\text{SbF}_6^-]$  has a low solubility in  $\text{SO}_2$ , these two solvents were used extensively to carry out metathesis reactions at  $-78^\circ\text{C}$  and  $-64^\circ\text{C}$ , respectively.

f. Write the balanced equation for the preparation of  $[\text{N}_5^+]_2[\text{SnF}_6^{2-}]$  and  $[\text{N}_5^+][\text{B}(\text{CF}_3)_4^-]$  in solution starting with  $[\text{Cs}^+]_2[\text{SnF}_6^{2-}]$  and  $[\text{K}^+][\text{B}(\text{CF}_3)_4^-]$ , respectively. Indicate the appropriate solvent.

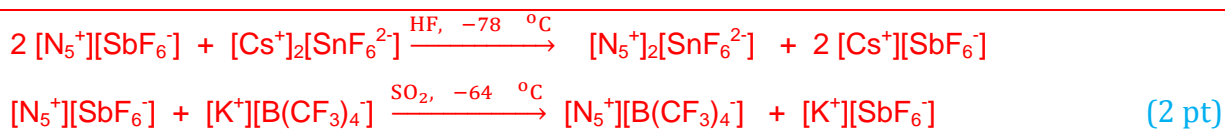

Name:

Code:

When  $[\text{N}_5^+]_2[\text{SnF}_6^{2-}]$  decomposes under carefully controlled conditions at 25-30 °C,  $[\text{N}_5^+][\text{SnF}_5^-]$  and  $\text{N}_5\text{F}$  are formed. The  $[\text{N}_5^+][\text{SnF}_5^-]$  salt is a white solid and has a thermal stability comparable to that of  $[\text{N}_5^+][\text{SbF}_6^-]$  (50 – 60 °C). The solution  $^{119}\text{Sn}$  NMR spectrum has shown that the  $\text{SnF}_5^-$  anion in this compound is, in fact, a mixture of dimeric and tetrameric polyanions. In both of these polyanions the coordination number of Sn atom is 6 and there are bridging fluorine atoms.

g. Draw the structures of dimeric and tetrameric polyanions.

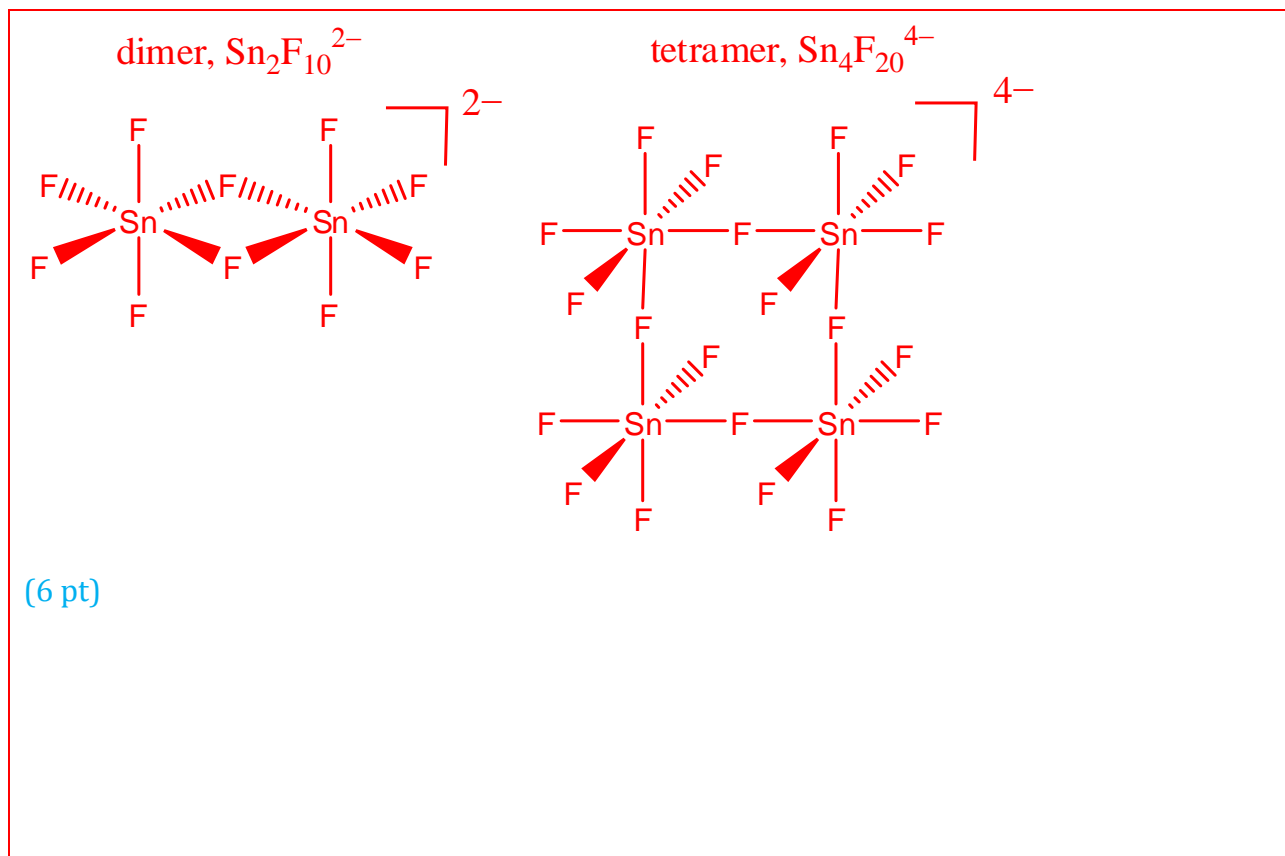



**Problem 6****7.0% of the total**

a	b	c	d	e	f	g	Problem 6	x%
5	3	4	2	5	3	1	23	7.0

Extraction of gold using sodium cyanide, a very poisonous chemical, causes environmental problems and gives rise to serious public concern about the use of this so called “cyanide process”. Thiosulfate leaching of gold has been considered as an alternative. In this process, the main reagent is ammonium thiosulfate,  $(\text{NH}_4)_2\text{S}_2\text{O}_3$ , which is relatively nontoxic. Although this process appears to be environmentally benign, the chemistry involved is very complex and needs to be studied thoroughly. The solution used for leaching gold contains  $\text{S}_2\text{O}_3^{2-}$ ,  $\text{Cu}^{2+}$ ,  $\text{NH}_3$ , and dissolved  $\text{O}_2$ . The solution must have a pH greater than 8.5 to allow free ammonia to be present.

According to the proposed mechanism, a local voltaic micro-cell forms on the surface of gold particles during the leaching process and operates as follows:

Anode:

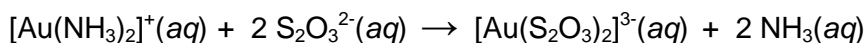
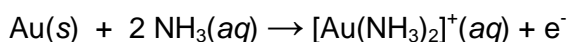

Cathode:

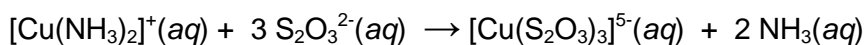

a. Write the overall cell reaction for this voltaic cell.

Net anode half reaction:

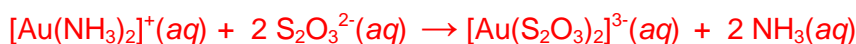

Net cathode half reaction:



Name:

Code:



Overall cell reaction:



(5 pt)

- b. In the presence of ammonia,  $\text{O}_2$  oxidizes  $[\text{Cu}(\text{S}_2\text{O}_3)_3]^{5-}$  back to  $[\text{Cu}(\text{NH}_3)_4]^{2+}$ . Write a balanced equation for this oxidation-reduction reaction in basic solution.

Oxidation half reaction:



Reduction half reaction:



Oxidation-Reduction Reaction:

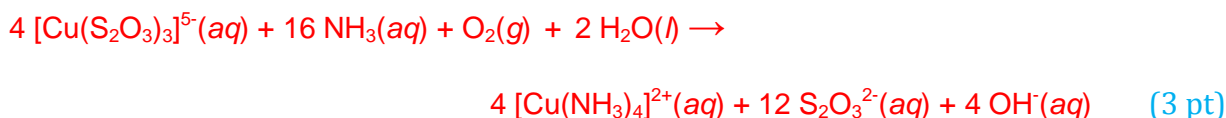

- c. In this leaching process, the  $[\text{Cu}(\text{NH}_3)_4]^{2+}$  complex ion functions as catalyst and speeds up the dissolution of gold. Write the net overall oxidation-reduction reaction for dissolution of the gold metal, which is catalyzed by  $[\text{Cu}(\text{NH}_3)_4]^{2+}$  complex ion.

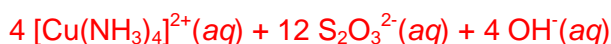
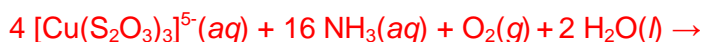

Name:

Code:

- d. Draw the coordination geometries of the metal in  $[\text{Au}(\text{NH}_3)_2]^+$  and  $[\text{Au}(\text{S}_2\text{O}_3)_2]^{3-}$  complex ions, indicating the coordinating atoms.

	$[\text{Au}(\text{NH}_3)_2]^+$	$[\text{Au}(\text{S}_2\text{O}_3)_2]^{3-}$
Coordination geometry	$[\text{H}_3\text{N}-\text{Au}-\text{NH}_3]^+$	$[\text{O}_3\text{S}-\text{S}-\text{Au}-\text{S}-\text{SO}_3]^{3-}$
	(2 pt)	

- e. The formation constants,  $K_f$ , of  $[\text{Au}(\text{NH}_3)_2]^+$  and  $[\text{Au}(\text{S}_2\text{O}_3)_2]^{3-}$  complexes are  $1.00 \times 10^{26}$  and  $1.00 \times 10^{28}$ , respectively. Consider a leaching solution, in which the equilibrium concentrations of the species are as follows:

$$[\text{S}_2\text{O}_3^{2-}] = 0.100 \text{ M}; [\text{NH}_3] = 0.100 \text{ M}; \text{total concentration of gold(I) species} = 5.50 \times 10^{-5} \text{ M}.$$

Calculate the percentage of gold(I) ion, which exists in the form of thiosulfate complex.

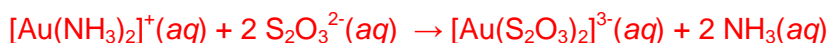

$$K_{\text{eq}} = K_f(2)/K_f(1) = 1.00 \times 10^2$$

$$[\text{Au}(\text{NH}_3)_2]^+ + [\text{Au}(\text{S}_2\text{O}_3)_2]^{3-} = 5.50 \times 10^{-5} \text{ M}$$

$$K_{\text{eq}} = \frac{(0.100)^2 x}{(5.50 \times 10^{-5} - x)(0.100)^2} = 1.00 \times 10^2, \quad x = 5.445 \times 10^{-5} \text{ M}$$

$$\frac{5.445 \times 10^{-5}}{5.50 \times 10^{-5}} \times 100 = 99.0 \text{ \% of Au(I) in the form of } [\text{Au}(\text{S}_2\text{O}_3)_2]^{3-}$$

(5 pt)

- f. When the concentration of  $\text{O}_2$  is not high enough and  $\text{pH} > 10$ ,  $\text{S}_2\text{O}_3^{2-}$  reduces  $[\text{Cu}(\text{NH}_3)_4]^{2+}$  to  $[\text{Cu}(\text{S}_2\text{O}_3)_3]^{5-}$  with the formation of tetrathionate ion,  $\text{S}_4\text{O}_6^{2-}$ :



In basic solution tetrathionate disproportionates to trithionate,  $\text{S}_3\text{O}_6^{2-}$ , and thiosulfate. Write a balanced equation for this disproportionation reaction.

Name:

Code:

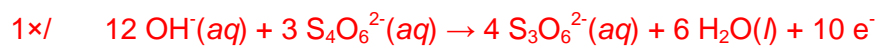
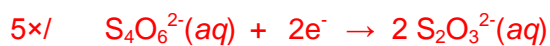

(3 pt)

- g.** When the  $\text{O}_2$  concentration is too high it oxidizes  $\text{S}_2\text{O}_3^{2-}$  to yield trithionate and sulfate ions. Write a balanced equation for this reaction.

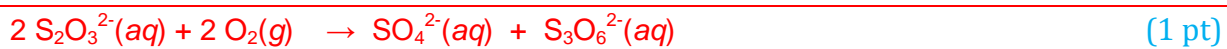

Name: \_\_\_\_\_

Code: \_\_\_\_\_

# Problem 7 8.5% of the total

A	S	B	C	D	E	F	G <sub>1</sub>	G <sub>2</sub>	H	I	J	K	L	M	1a	1b	Problem 7	x%
2	2	2	2	2	2	1	1	1	2	2	2	1	1	1	1	1	26	8.5

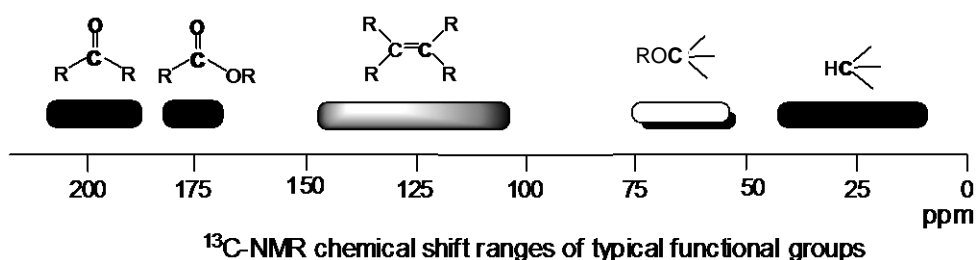

## Synthesis of a carbasugar

Carbohydrates are essential components of living cells and a source of energy for animals. They include simple sugars with small molecules as well as macromolecular substances. When the ring oxygen (endocyclic oxygen) in sugars is replaced by a methylene group, the compounds formed are called as **pseudosugars** or **carbasugars**. Since carbasugars are hydrolytically stable towards acids and enzymes, several carbasugars have found application in the field of glycosidase inhibition.

The total syntheses of two isomeric carbasugar having skeleton **1** are described below.

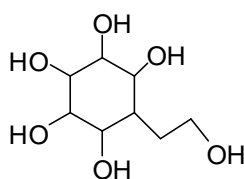

**1**

The total synthesis of **1** starts with a reduction of benzene by sodium in liquid ammonia to give **A**. The C-13 NMR spectrum of **A** consists of two signals at 124.0 and 26.0 ppm.

Trichloroacetyl chloride in the presence of Zn gives a reactive species **S**. One equivalent of **S** undergoes [2+2] cycloaddition with **A** to form a racemic product **B**. The reaction of **B** with Zn in acetic acid gives **C**. Compound **C** contains only carbon, hydrogen and oxygen: The C-13 NMR spectrum of **C** exhibits three sp<sup>2</sup> carbon signals at 210.0, 126.5 and 125.3 ppm.

Name: \_\_\_\_\_

Code: \_\_\_\_\_

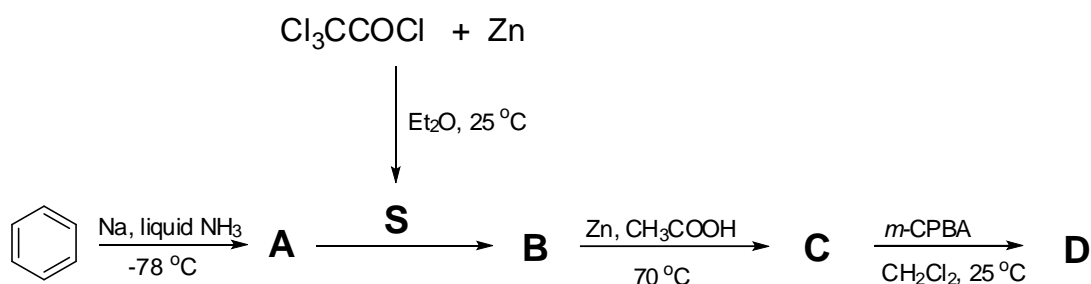

The reaction of **C** with one equivalent *m*-chloroperbenzoic acid (*m*-CPBA) in methylene chloride gives **D** as a major product. The C-13 NMR spectrum of **D** exhibits also three signals in the sp<sup>2</sup> region at 177.0, 125.8, 124.0 ppm.

Draw the structures of **A**, **B**, **C**, **D**, and the intermediate **S**.

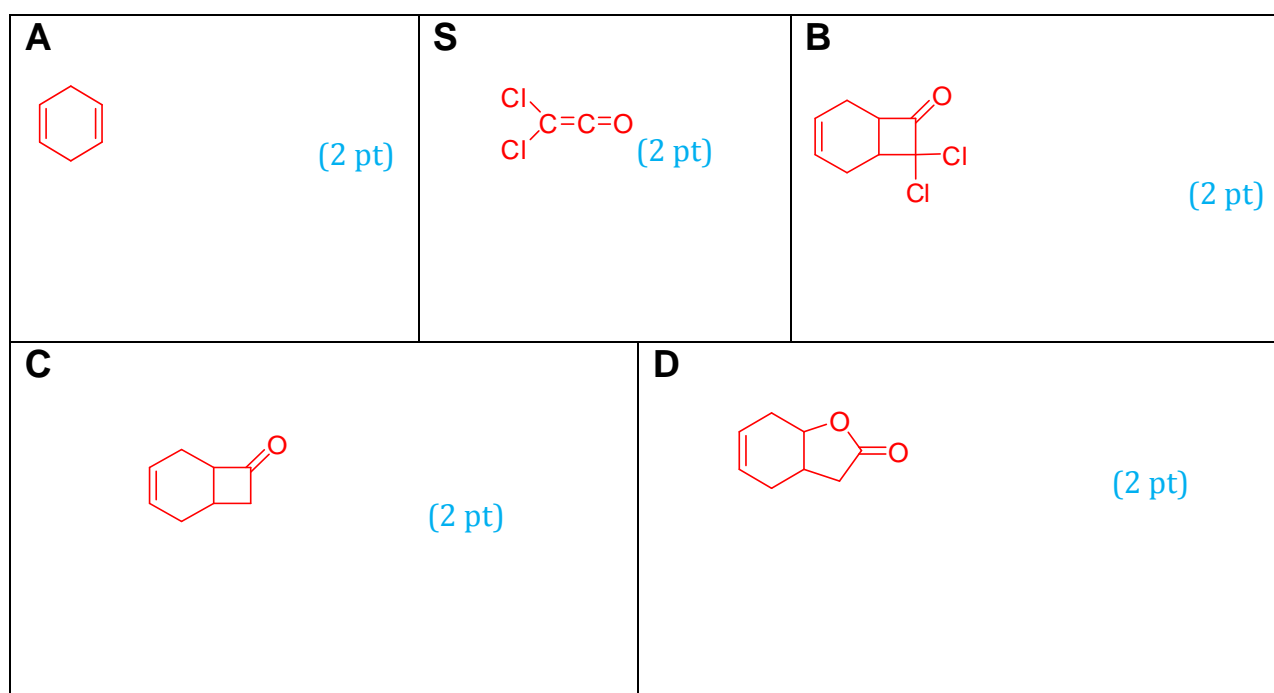

Reduction of **D** with LiAlH<sub>4</sub> yields **E**, which reacts with excess acetyl chloride in pyridine to give **F**. Draw the structures (use one enantiomer) of **E** and **F** using dashed-wedged line notation. Assign the configurations (*R* or *S*) at the asymmetric carbon atoms in **E**.

The compound **F** (use the drawn enantiomer) is reacted with bromine to give the stereoisomers **G**<sub>1</sub> and **G**<sub>2</sub>. Draw the structures of **G**<sub>1</sub> and **G**<sub>2</sub> using dashed-wedged line notation.

A mixture of **G**<sub>1</sub> and **G**<sub>2</sub> is reacted with two equivalents of 1,8-diazabicyclo[5.4.0]undec-7-ene (DBU), which is a strong amine base, to afford **H**. Draw the structure of **H** using dashed-wedged line notation.

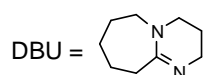
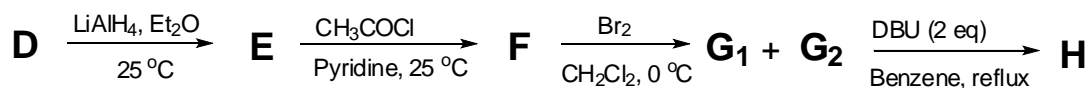

Name:

Code:

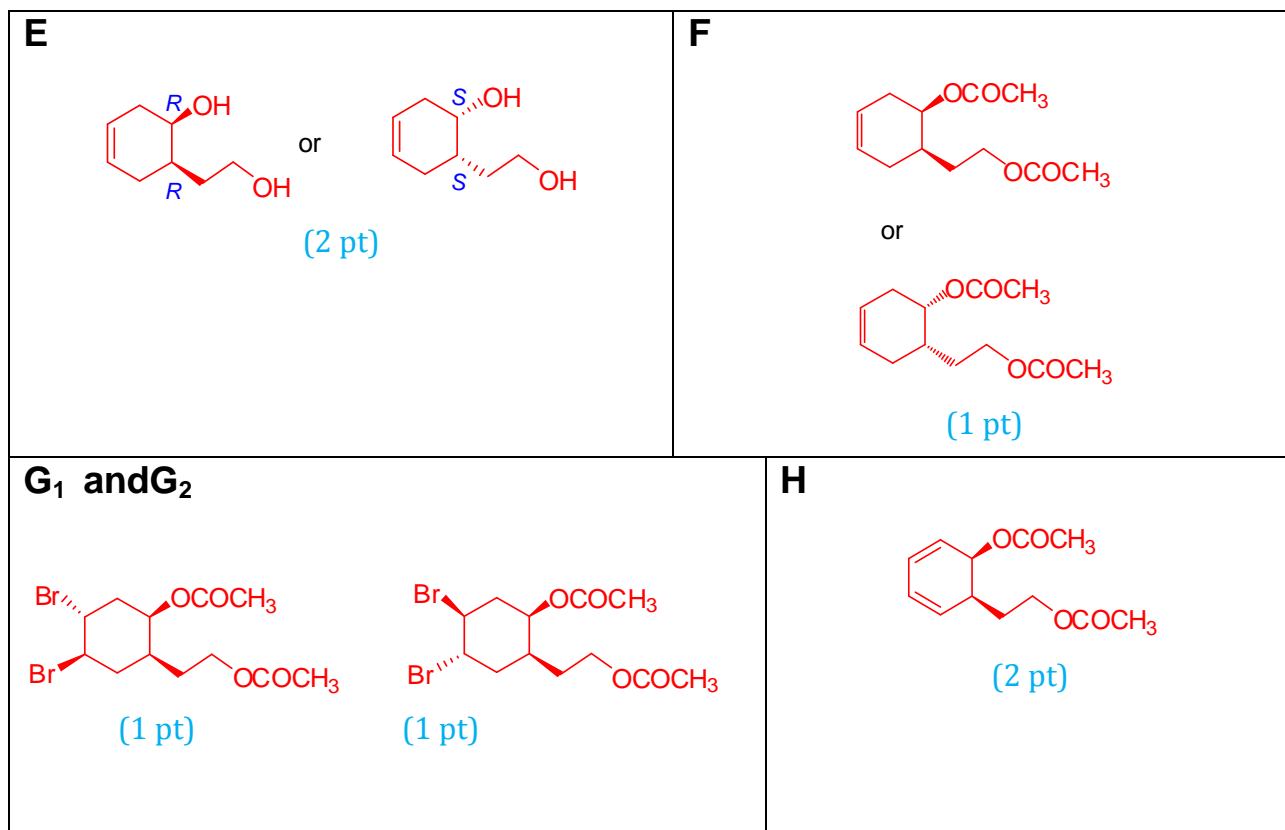

Reaction of **H** with singlet oxygen (in situ generated) affords **I**. Although two isomers are theoretically possible, **I** is formed as the single isomer due to steric hindrance and electronic repulsion.

The reaction of **I** with excess  $\text{LiAlH}_4$  results in the formation of **J**. The C-13 NMR spectrum of **J** shows 8 signals, two in the  $\text{sp}^2$  region.

Reaction of **J** with excess acetyl chloride in the presence of pyridine yields **K**. Subsequent reaction of **K** with  $\text{OsO}_4$  in the presence of 4-methylmorpholine 4-oxide (NMO) gives stereoisomers **L** and **M**.

Upon reduction with excess  $\text{LiAlH}_4$ , **L** and **M** give the stereoisomers **1a** and **1b**, respectively.

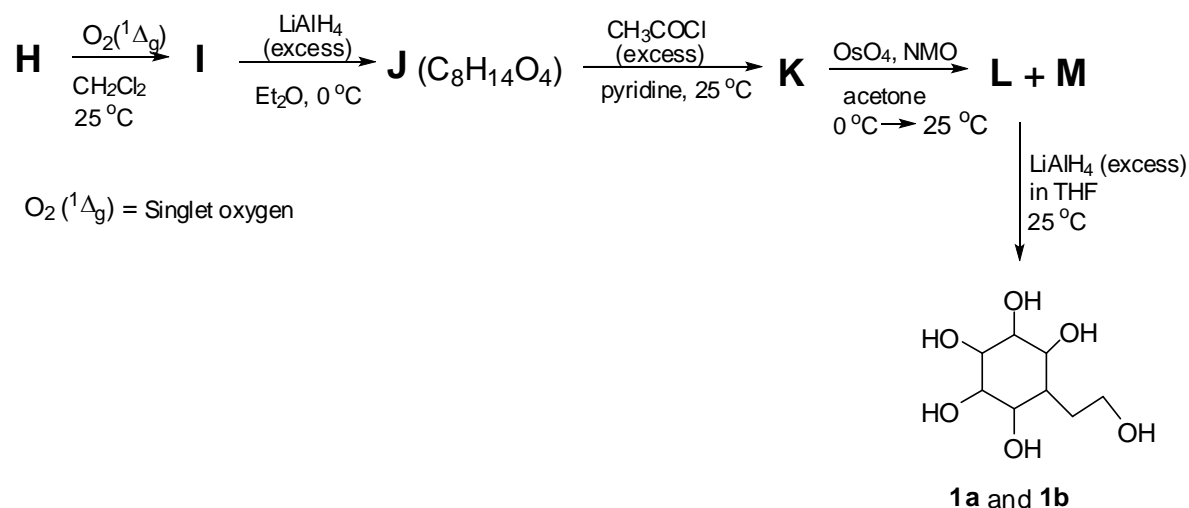

Name:

Code:

Draw the structures of **I**, **J**, **K**, **L**, **M**, **1a**, and **1b** using dashed-wedged line notation.

<p><b>I</b></p> <p>(1 + 1 pt)</p>	<p><b>J</b></p> <p>(1 + 1 pt)</p>
<p><b>K</b></p> <p>(1 pt)</p>	<p><b>L and M</b> (1 + 1 pt)</p>
<p><b>1a and 1b</b> (1 + 1 pt)</p>	



# Problem 8 6.5% of the total

B	C	D	E	F	G	H	I	J	K	L	M	Problem 8	x%
2	2	2	2	1	1	1	1	1.5	1.5	1.5	1.5	18	6.5

Click chemistry is a chemical concept introduced by K. B. Sharpless in 2001 and describes a set of chemical reactions that generate substances quickly, reliably and quantitatively by joining molecules through small units under mild conditions. This methodology has recently been applied as a key step in the following synthesis of bicyclic compounds.

Mandelic acid is a versatile natural compound and widely used as a "chiral pool" in synthesis. The reduction of (*R*)-mandelic acid with  $\text{LiBH}_4$  affords **A**.

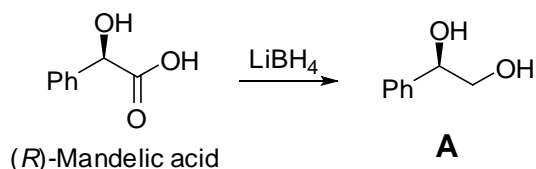

Reaction of **A** with 1 equivalent *p*-toluenesulfonyl chloride gives **B**. Heating **B** in pyridine yields **C**. During this transformation, compounds **B** and **C** retain their absolute configurations.

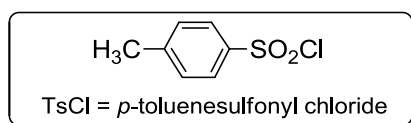
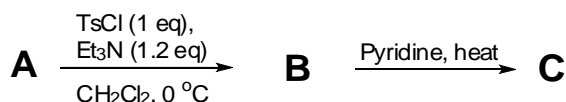

Draw the structures of **B** and **C** with the correct stereochemistry. Use dashed-wedged line notation throughout this problem.

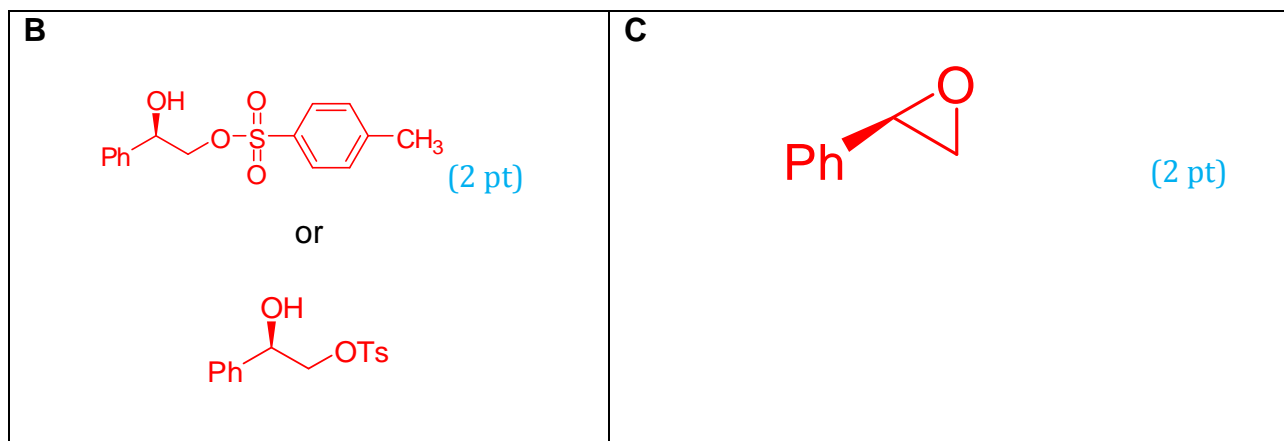

Name:

Code:

Reaction of **C** with sodium azide in aqueous acetonitrile gives a mixture of enantiopure regioisomers **D** and **E** in a ratio of 3:1. On the other hand, the compound **B** affords **E** as the sole product under the same condition.

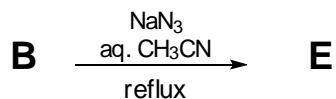
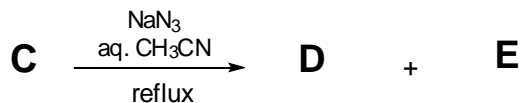

Draw the structures of **D** and **E** with the correct stereochemistry.

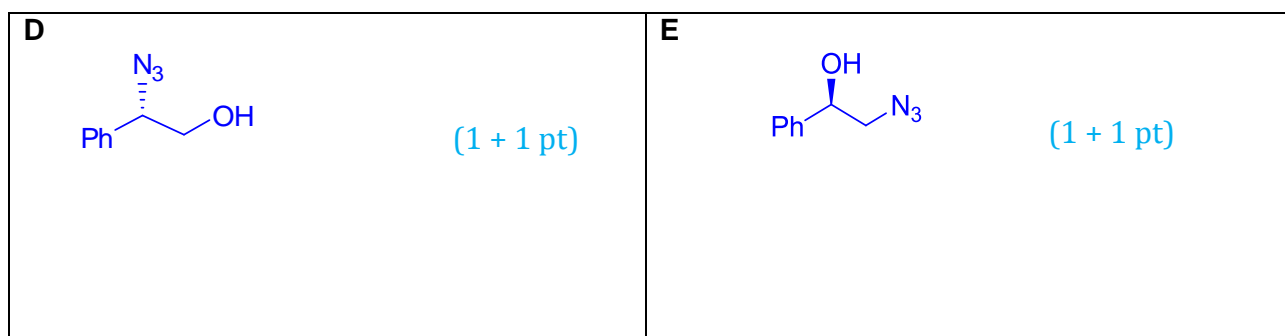

**Part I:** Compounds **D** and **E** are separately subjected to NaH mediated reaction with 3-bromoprop-1-yne to afford **F** and **G**, respectively. Heating **F** and **G** separately in toluene gives the bicyclic products **H** and **I**, respectively.

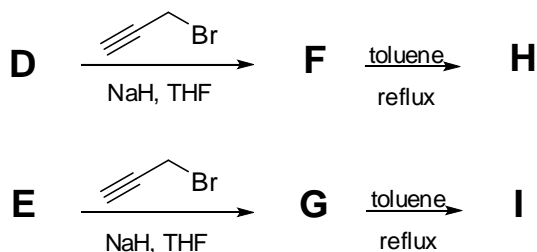

Draw the structure of compounds **F**, **G**, **H** and **I** with the correct stereochemistry.

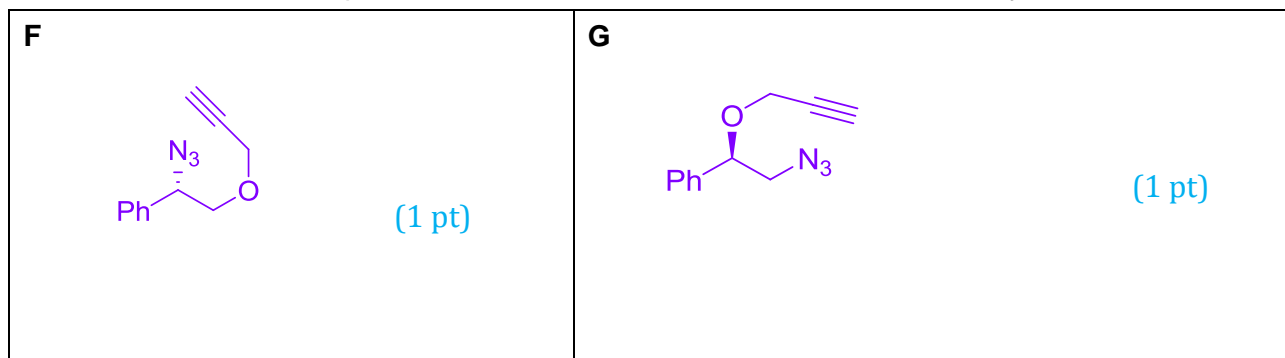

Name:

Code:

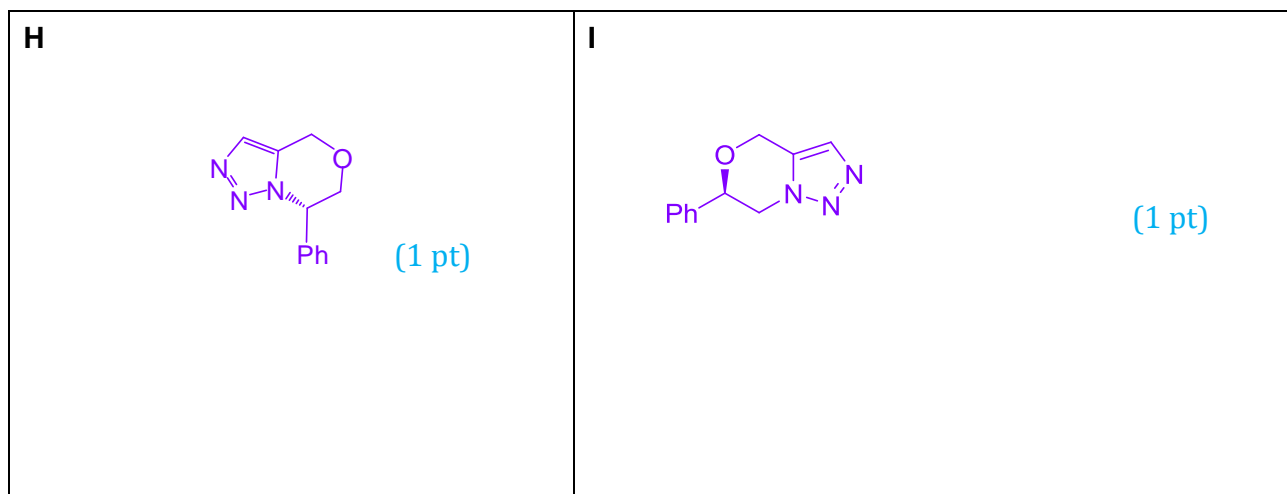

**Part II:** Reaction of **D** and **E** separately with dimethyl acetylenedicarboxylate in water at 70°C forms the optically active monocyclic regioisomers **J** and **K**, respectively. Subsequent treatment of **J** and **K** with NaH gives final bicyclic products **L** and **M**, respectively, both having the formula C<sub>13</sub>H<sub>11</sub>N<sub>3</sub>O<sub>4</sub>.

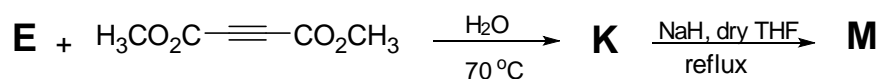
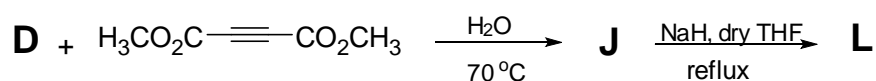

Draw the structures of compound **J**, **K**, **L** and **M** with the correct stereochemistry.

